



US006610554B2

(12) **United States Patent**  
**Yi et al.**

(10) **Patent No.:** **US 6,610,554 B2**  
(45) **Date of Patent:** **Aug. 26, 2003**

(54) **METHOD OF FABRICATING ORGANIC ELECTROLUMINESCENT DISPLAY**

(75) Inventors: **Seung-jun Yi**, Seoul (KR); **Do-hyun Choi**, Seoul (KR); **Kyung-hee Choi**, Seoul (KR)

(73) Assignee: **Hyung Se Kim**, Kyunggi-Do (KR)

(\*) Notice: Subject to any disclaimer, the term of this patent is extended or adjusted under 35 U.S.C. 154(b) by 0 days.

5,294,870 A	3/1994	Tang et al.	
5,399,502 A	3/1995	Friend et al.	
5,475,514 A	* 12/1995	Salerno et al.	..... 359/41
5,807,627 A	9/1998	Friend et al.	
6,097,147 A	8/2000	Baldo et al.	
6,100,104 A	* 8/2000	Haerle	..... 438/33
6,188,420 B1	* 2/2001	Kuribayashi et al.	..... 347/132
2002/0068373 A1	* 6/2002	Lo et al.	..... 438/33
2002/0158577 A1	* 10/2002	Shimoda et al.	..... 313/506

\* cited by examiner

(21) Appl. No.: **10/119,780**

(22) Filed: **Apr. 11, 2002**

(65) **Prior Publication Data**

US 2002/0187255 A1 Dec. 12, 2002

(30) **Foreign Application Priority Data**

Apr. 18, 2001	(KR)	.....	2001-0020689
Mar. 18, 2002	(KR)	.....	2002-0014622

(51) **Int. Cl.**<sup>7</sup> ..... **H01L 21/00**

(52) **U.S. Cl.** ..... **438/33**; 438/22; 438/34; 438/47; 427/289; 427/290

(58) **Field of Search** ..... 438/22, 33, 34, 438/35, 23, 24, 25, 26, 27, 28, 29-32, 36-47; 427/289, 290, 292

(56) **References Cited**

**U.S. PATENT DOCUMENTS**

4,769,292 A 9/1988 Tang et al.

*Primary Examiner*—Matthew Smith

*Assistant Examiner*—Renzo N. Rocchegiani

(74) *Attorney, Agent, or Firm*—Birch, Stewart, Kolasch & Birch, LLP

(57) **ABSTRACT**

Described is a method of fabricating an organic electroluminescent display (hereinafter abbreviated OELD) enabling to increase a throughput efficiency by carrying out a foregoing OELD process, dividing a large-scaled substrate, and carrying out a following OELD process in order. The present invention includes the steps of forming a first electrode layer on a large-scaled substrate, dividing the large-scaled substrate into a plurality of small substrates, forming an organic electroluminescent layer on the first electrode layer of at least one of the small substrates, and forming a second electrode layer on the organic electroluminescent layer.

**16 Claims, 7 Drawing Sheets**

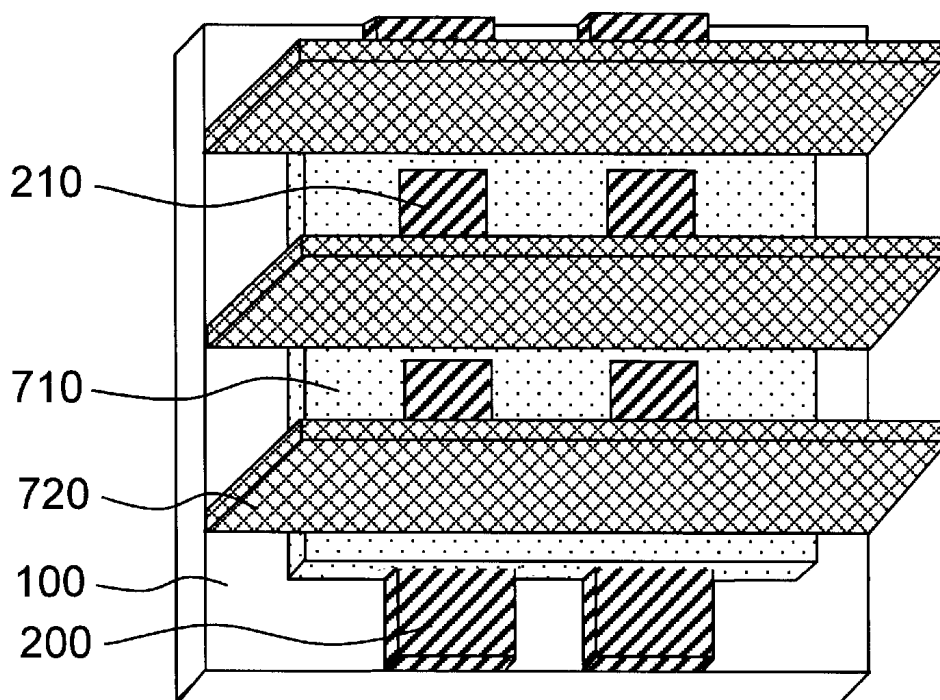

FIG. 1A

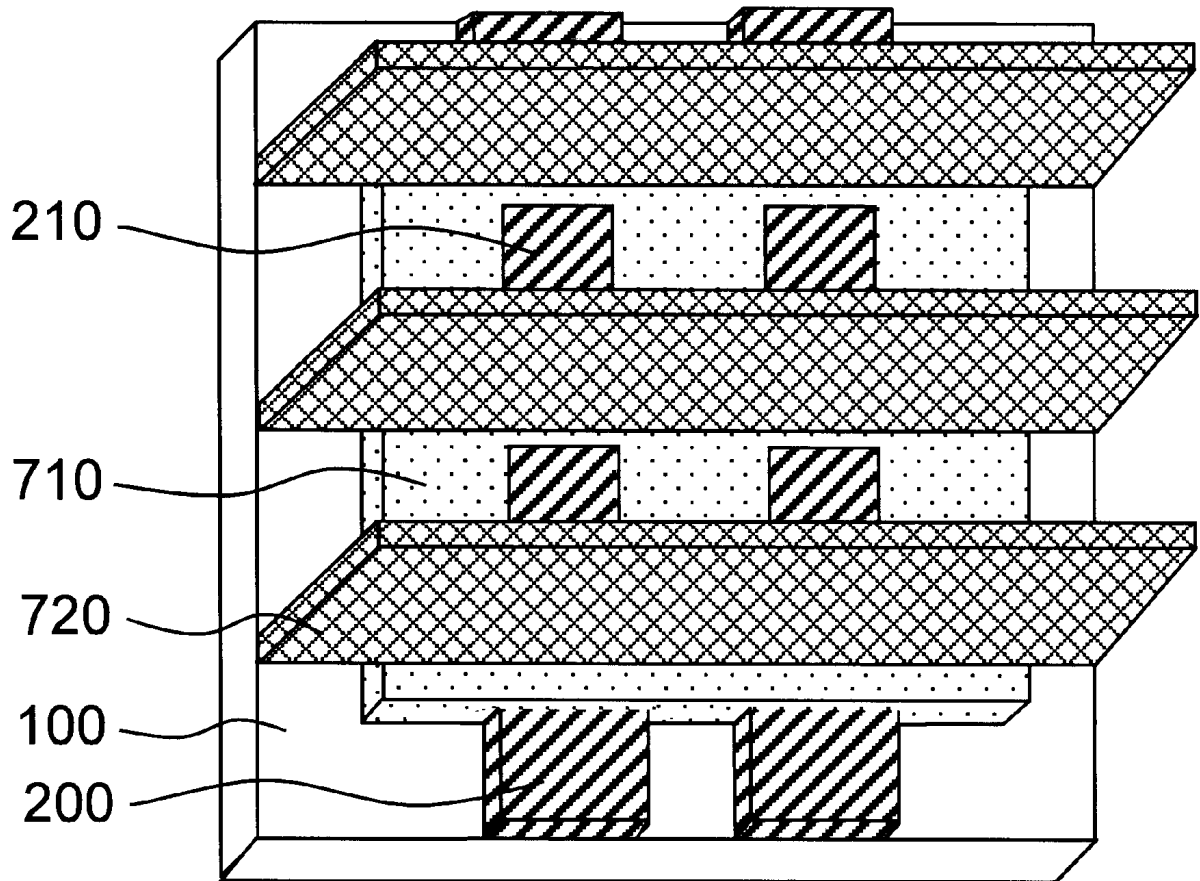

FIG. 1B

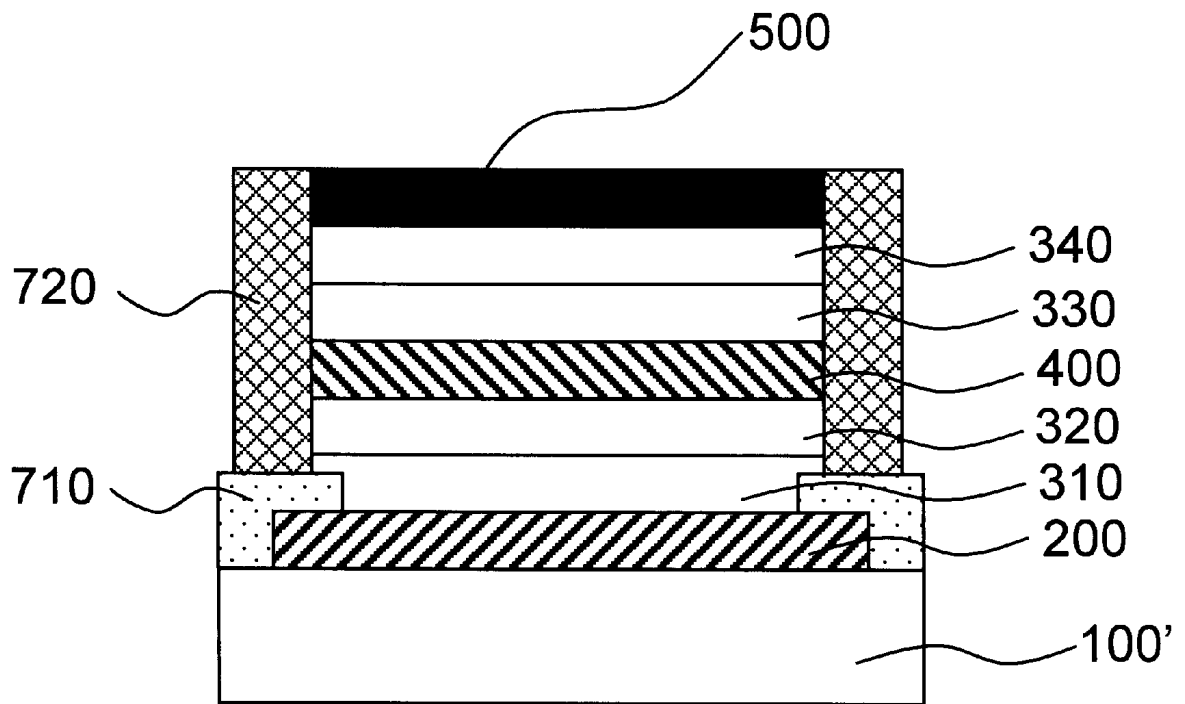

FIG. 2A

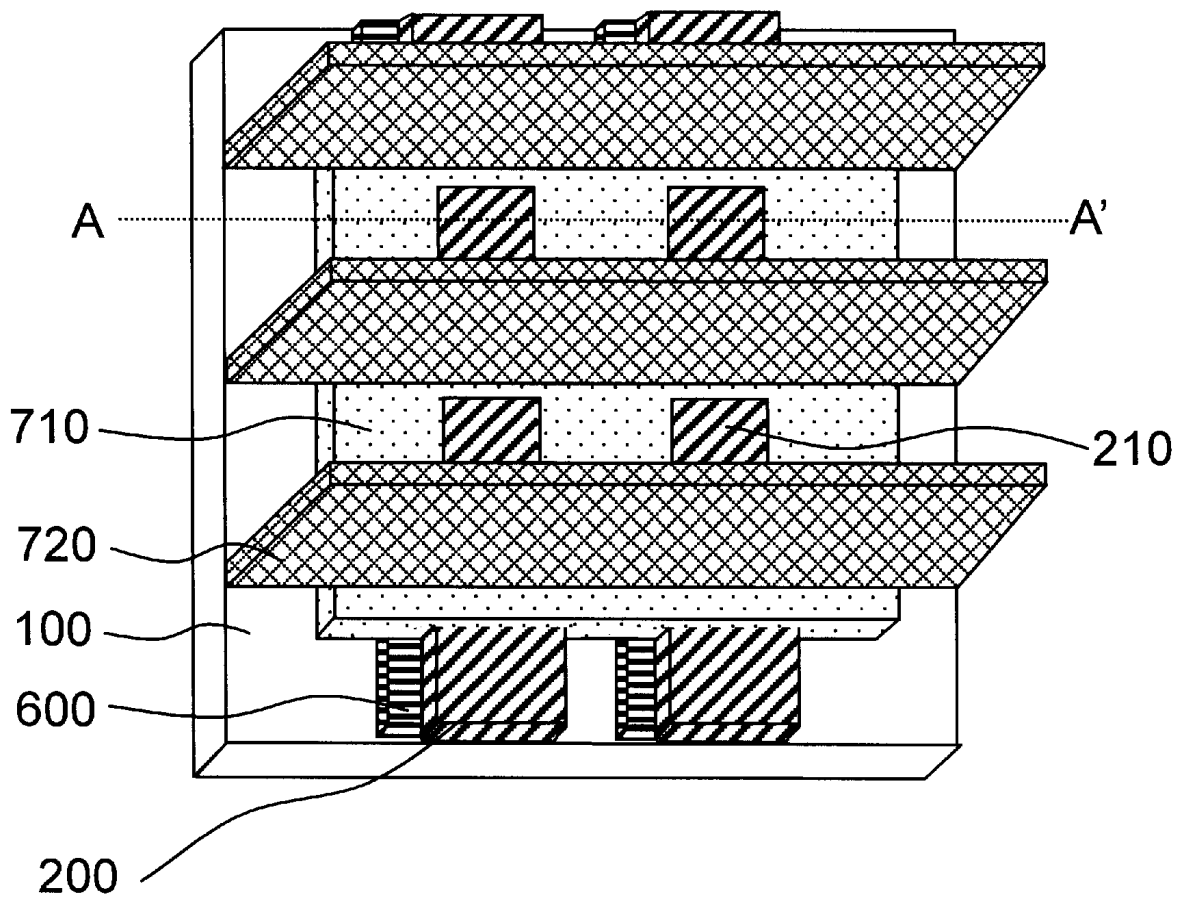

FIG. 2B

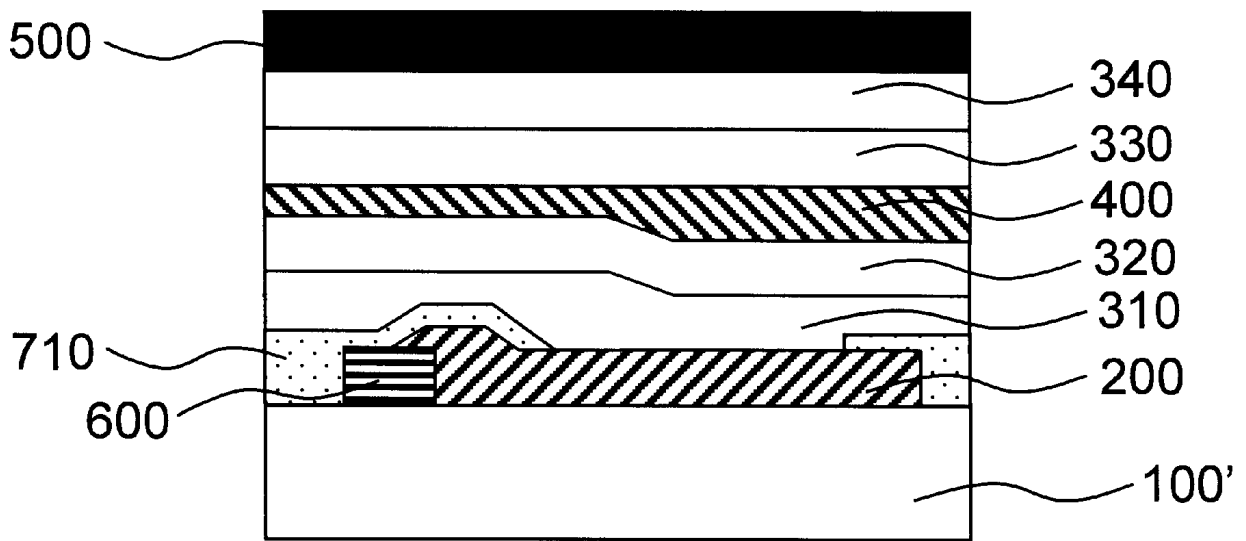

FIG. 3A

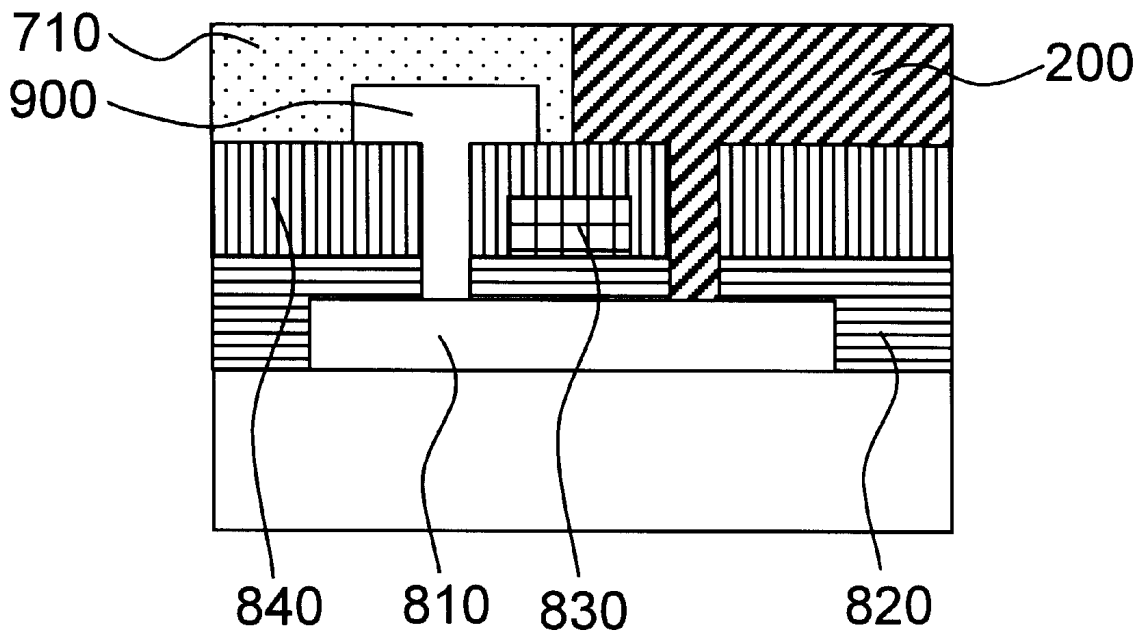

FIG. 3B

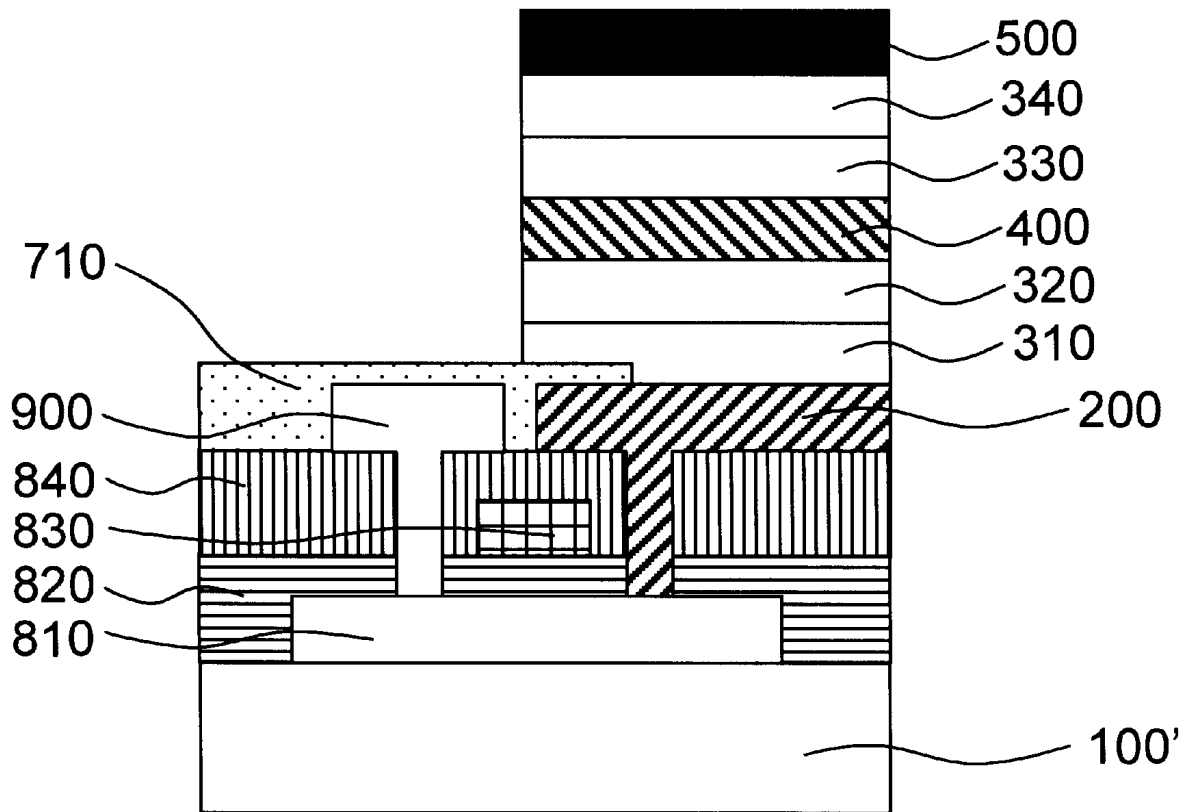
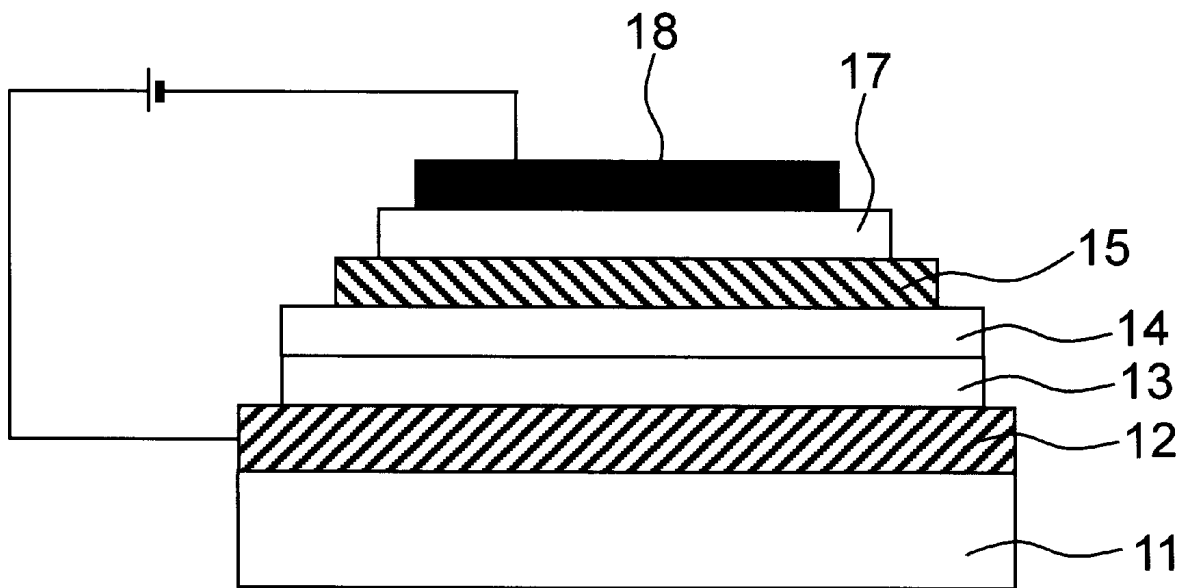

FIG. 4



# METHOD OF FABRICATING ORGANIC ELECTROLUMINESCENT DISPLAY

## BACKGROUND OF THE INVENTION

### 1. Field of the Invention

The present invention relates to an organic electroluminescent display, and more particularly, to a method of fabricating an organic electroluminescent display (hereinafter abbreviated OELD) enabling to increase a throughput efficiency by carrying out a foregoing OELD process, dividing a large-scaled substrate, and carrying out a following OELD process in order.

### 2. Background of the Related Art

As information telecommunication technologies have been greatly developed, demands for electronic display devices are highly increased to keep up with the developing information society. And, so does the demands for various displays. In order to satisfy the demands of the information society, for electronic display devices are required characteristics such as high-resolution, large-size, low-cost, high-performance, slim-dimension, and small-size and the like, for which new flat panel displays (hereinafter abbreviated FPD) are developed as substitutions for the conventional cathode ray tube (CRT).

The FPDs include LCD (liquid crystal display), ELD (electroluminescent display), PDP (plasma display panel), FED (field emission display), VFD (vacuum fluorescence display), and LED (light emitting display), and the like.

Compared to the non-emissive device such as LCD, ELD attracts attention as the next generation FPD because ELD has a response speed faster than that of the non-emissive display, excellent brightness by self-luminescence, easy fabrication thanks to a simple structure, and light-weight/slim design. Thus, ELD is widely applied to various fields such as LCD backlight, mobile terminal, car navigation system (CNS), notebook computer, wall TV, and the like.

Such an ELD is divided into two categories, i.e. organic electroluminescent display (hereinafter abbreviated OELD) and inorganic electroluminescent display (hereinafter abbreviated IELD) in accordance with materials used for luminescent layers respectively.

IELD, which emits light using the collisions of electrons accelerated by an high electric field, is classified into AC thin film ELD, AC thick film ELD, DC thick film ELD, and the like in accordance with thickness of the thin films and driving systems.

And, OELD, which emits light by a current flow, is classified into low-molecular OELD and high-molecular OELD.

FIG. 4 illustrates a schematic cross-sectional view of OELD according to a related art.

Referring to FIG. 4, stacked on a transparent substrate **11** in order are a transparent anode layer **12**, a hole injection layer **13**, a hole transport layer **14**, an organic luminescent layer **15**, an electron transport layer **17**, and a cathode layer **18** made of metal. And, the organic luminescent layer **15** emits light by a current flow. The hole injection, hole transport, and electron transport layers **13**, **14**, and **17** play a subsidiary role in increasing a luminescence efficiency of OELD.

The hole injection, hole transport, organic luminescent, and electron transport layers **13**, **14**, **15**, and **17** are formed by vacuum deposition using a shadow mask if formed of a low molecular material. And, the hole transport, and organic

luminescent layers **14**, and **15** are formed by ink-jet or printing if formed of a high molecular material. The limitation of the deposition or printing equipment restricts the size of a substrate. The maximum size of the substrate enabling to use the current deposition or printing equipment for the deposition or printing is 370 mm×470 mm or 400 mm×400 mm.

OELD is classified into the following devices in accordance with the luminescent (light-emitting) materials. First, there is a fluorescent display disclosed in U.S. Pat. Nos. 4,769,292 and 5,294,870, in which the organic luminescent layer **15** is formed of a fluorescent emitting material such as aluminum tris(8-hydroxyquinoline) (Alq3), perylene or the like. Second, there is phosphorescent OELD disclosed in U.S. Pat. No. 6,097,147, in which the organic luminescent layer **15** is formed of one of phosphorescent emitting materials such as platinum 2,3,7,8,12,12,17,18-octaethyl-21H,23H-porphine platinum (PtOEP), iridium complex {ex. Ir (Ppy) 3} and a blocking layer is formed between the hole and electron transport layers **14** and **17** using one of bathocuproine (BCP), cabazole biphenyl (CBP), N,N'-diphenyl-N,N'-bis-alpha-naphthylbenzylidene (NPD), and the like. Specifically, high molecular OELD has a double-layered structure including hole transport/electroluminescent layers **14/15** between the transparent anode and cathode layers **12** and **18**, for which conductive high molecules of conjugated polymer disclosed in U.S. Pat. No. 5,399,502 and U.S. Pat. No. 5,807,627 are used. The conductive polymer includes {poly(p-phenylenevinylene), PPV}, poly(thiophene), {poly(2,5-dialkoxyphenylenevinylene, PDMeOPV)}, and the like.

Luminescent wavelengths of the representative organic electroluminescent materials are shown in Table 1.

TABLE 1

Organic electroluminescent material	Wavelength of emitting light
4,4-bis (2,2'-diphenylethen-4-yl)-diphenyl	465 nm
Tris (8-hydroxyquinoline) aluminum	520 nm
bis (8-hydroxyquinoline) magnesium	515 nm
Coumarine 6	503 nm
Rubrene	560 nm
poly (p-phenylenevinylene), PPV	540 nm

Such OELD is classified into active and passive types according to its driving system. If the panel size of the passive type OELD driven by current increases, an efficiency of power consumption as well as device reliance decreases. In order to settle such problems, if a diagonal diameter of a panel is at least 10", the active type OELD using polysilicon thin film transistors (hereinafter abbreviated TFT) is used.

Unfortunately, OELD according to the related art has the following problems or disadvantages.

The electroluminescent layer of OELD is formed by deposition using a shadow mask or printing. Thus, the limitation of equipments of deposition or printing restricts the size of the substrate. The available size of the substrate is maximum 370 mm×470 mm or 400 mm×400 mm.

Therefore, such a restriction of the substrate size also restricts productivity (throughput) of OELD so as to increase a product cost.

## SUMMARY OF THE INVENTION

Accordingly, the present invention is directed to a method of fabricating an organic electroluminescent display that

substantially obviates one or more of the problems due to limitations and disadvantages of the related art.

An object of the present invention is to provide a method of fabricating an organic electroluminescent display (hereinafter abbreviated OELD) enabling to increase a throughput efficiency by carrying out a foregoing OELD process, dividing a large-scaled substrate, and carrying out a following OELD process in order.

Additional features and advantages of the invention will be set forth in the description which follows, and in part will be apparent from the description, or may be learned by practice of the invention. The objectives and other advantages of the invention will be realized and attained by the structure particularly pointed out in the written description and claims hereof as well as the appended drawings.

To achieve these and other advantages, and in accordance with the purpose of the present invention as embodied and broadly described, a method of fabricating an organic electroluminescent display includes the steps of forming a first electrode layer on a large-scaled substrate, dividing the large-scaled substrate into a plurality of small substrates, forming an organic electroluminescent layer on the first electrode layer of at least one of the small substrates, and forming a second electrode layer on the organic electroluminescent layer.

In another aspect of the present invention, a method of fabricating an organic electroluminescent display includes the steps of forming a driving part including a plurality of transistors and at least one capacitor and having a first electrode layer on a large-scaled substrate, dividing the large-scaled substrate into a plurality of small substrates, forming an organic electroluminescent layer on the first electrode layer of the driving part of at least one of the small substrates, and forming a second electrode layer on the organic electroluminescent layer.

It is to be understood that both the foregoing general description and the following detailed description are exemplary and explanatory and are intended to provide further explanation of the invention as claimed.

#### BRIEF DESCRIPTION OF THE DRAWINGS

The accompanying drawings, which are included to provide a further understanding of the invention and are incorporated in and constitute a part of this specification, illustrate embodiments of the invention and together with the description serve to explain the principles of the invention.

In the drawings:

FIG. 1A illustrates a bird's-eye view of a passive type OELD according to a first embodiment of the present invention;

FIG. 1B illustrates a cross-sectional view of a passive type OELD according to a first embodiment of the present invention;

FIG. 2A illustrates a bird's-eye view of a passive type OELD according to a second embodiment of the present invention;

FIG. 2B illustrates a cross-sectional view of a passive type OELD according to a second embodiment of the present invention;

FIG. 3A and FIG. 3B illustrate cross-sectional view of fabricating active type OELD according to a third embodiment of the present invention; and

FIG. 4 illustrates a schematic cross-sectional view of OELD according to a related art.

#### DETAILED DESCRIPTION OF THE PREFERRED EMBODIMENTS

Reference will now be made in detail to the preferred embodiments of the present invention, examples of which

are illustrated in the accompanying drawings. Where possible, the same reference numerals will be used to illustrate like elements throughout the specification. And, detailed component materials and techniques of the embodiments of the present invention include all those used for the related art.

#### First Embodiment

A method of fabricating a passive type organic electroluminescent display (hereinafter abbreviated OELD) according to a first embodiment of the present invention is described as follows.

FIG. 1A illustrates a bird's-eye view of a passive type OELD according to a first embodiment of the present invention, and FIG. 1B illustrates a cross-sectional view of a passive type OELD according to a first embodiment of the present invention.

Referring to FIG. 1A, an ITO (indium tin oxide) layer (not shown in the drawing) is formed on a large-scaled substrate **100** made of transparent plastic or glass. In this case, a size of the substrate **100** includes 740 mm×940 mm. The ITO layer is coated with photoresist. After the photoresist is developed, an anode layer **200** is formed stripe-like by etching the ITO layer.

After a dielectric layer is formed on the anode layer **200**, a photoresist layer (not shown in the drawing) is coated on the insulating layer **710** to pattern the dielectric layer **710**. Exposure and development are carried out on the photoresist layer so as to form a photoresist pattern (not shown in the drawing). The dielectric layer **710** is etched using the photoresist pattern so as to form a plurality of openings **210** exposing predetermined portions of the anode layer **200**. In this case, the openings **210** over the anode layer **200** are left apart from each other with predetermined intervals.

A photoresist for separators is coated on the dielectric layer **710**. Exposure and development are carried out on the photoresist for separators, and a high thermal baking process is carried out thereon so as to form a plurality of separators **720** on the dielectric layer. In this case, the separators **720** are formed so as to be vertical to the anode layer **200**.

In this case, when the anode layer **200**, dielectric layer **710**, and separators **720** are formed, a scribing lane (not shown in the drawing) is prepared to cut the large-scaled substrate **100**. A width of the scribing lane is between 50  $\mu\text{m}$ ~1 mm.

The 740 mm×940 mm large-scaled substrate **100** is cut so as to be divided into four 370 mm×470 mm small substrates **100'** suitable for deposition. The large-scaled substrate **100** is cut using one of laser, supersonic waves, diamond, and the like. In order to remove particles generated from the cutting process of the large-sized substrate **100**, a cleaning process is carried out using wet cleaning, dry cleaning of UV or plasma, or both wet and dry cleaning.

Referring to FIG. 1B, a hole injection layer **310** is formed with CuPC, m-MTDATA, or the like on the anode layer **200** exposed through a plurality of the openings **210** over the small substrate **100'** of 370 mm×470 mm using a shadow mask. And, a hole transport layer **320** is formed with NBP on the hole injection layer **310** using a shadow mask.

And, an organic electroluminescent layer **400** is formed on the hole transport layer **320** using a shadow mask so as to include red, green, and blue pixels. In this case, the red pixel is formed using Alq3+DCJTb or the like, the green pixel is formed using Alq3+Qd2 or the like, and the blue pixel is formed using Blq+perylene or the like. An electron

transport layer **330** is formed with a material such as Alq3 or the like on the organic electroluminescent layer **400** using a shadow mask.

Subsequently, an electron injection layer **340** is formed on the electron transport layer **330**. A cathode layer **500** is then formed by vacuum deposition using a metal such as Al. In this case, the electron injection layer **340** prevents the injected holes from flowing into the cathode, and improves electron injection efficiency from the cathode, thereby increasing a luminescent efficiency. Further, a passivation layer (not shown in the drawing) may preferably be formed on the cathode layer **500** using an organic or inorganic material, or a metal or glass cap (not shown in the drawing) to which a desiccant is attached may be installed on the cathode layer **500**.

Moreover, for OLED using polymer, organic electroluminescent and subsidiary layers of thin films are formed by ink jet, printing, spin coating or the like. And, materials for the thin films include the foregoing-mentioned materials. Low molecular materials include the foregoing-mentioned materials as well.

On the other hand, the cathode layer **500** may be formed prior to the anode layer **200** in the first embodiment of the present invention.

#### Second Embodiment

A method of fabricating a passive type organic electroluminescent display having auxiliary electrodes according to a second embodiment of the present invention is described as follows.

FIG. 2A illustrates a bird's-eye view of a passive type OLED according to a second embodiment of the present invention, and FIG. 2B illustrates a cross-sectional view of a passive type OLED bisected along a cutting line a-a' in FIG. 2A according to a second embodiment of the present invention, in which separators are not shown.

Referring to FIG. 2A, a large-scaled substrate **100** formed of a transparent plastic or glass is cleaned. In this case, a size of the substrate **100** may be 740 mm×940 mm. A metal layer such as Cr, W, Mo, MoW, Al, or the like is deposited on the large-scaled substrate **100** by sputtering. A photoresist pattern is formed on the metal layer by coating, exposure and development. The metal layer is etched using the photoresist pattern as a mask so as to form auxiliary electrodes **600** like stripes. The auxiliary electrodes **600** are formed to reduce resistance of the following anode layer **200**.

And, using the same method of the first embodiment of the present invention, a dielectric layer **710** and separators **720** are formed on the large-scaled substrate **100** including the anode layer **200** in order. A scribing lane (not shown in the drawing) is then prepared to cut the large-scaled substrate **100**. A width of the scribing lane is between 50 μm~1 mm.

After an ITO (indium tin oxide) layer is formed on the large-scaled substrate **100** including the auxiliary electrodes **600**, a photoresist layer (not shown in the drawing) is coated on the ITO layer. Exposure and development are carried out on the photoresist layer so as to form a photoresist pattern (not shown in the drawing). The ITO layer is etched using the photoresist, pattern so as to form the anode layer **200** on the auxiliary electrodes **600**. In this case, the anode layer **200** is formed stripe-like so as to be parallel to the auxiliary electrodes **600**.

The 740 mm×940 mm large-scaled substrate **100** is cut so as to be divided into four 370 mm×470 mm small substrates

**100'** suitable for deposition. The large-scaled substrate **100** is cut using one of laser, supersonic waves, diamond, and the like. In order to remove particles generated from the cutting process of the large-sized substrate **100**, a cleaning process is carried out using wet cleaning, dry cleaning of UV or plasma, or both wet and dry cleaning.

Subsequently, as is the case with the first embodiment of the present invention, hole injection, hole transport, electroluminescent, electron transport, and electron injection layers **310**, **320**, **400**, **330**, and **340** are formed on the small substrate **100'** of 370 mm×470 mm. In this case, these layers are formed by vacuum deposition in case of low molecules or one of ink-jet, printing, and spin-coating in case of high molecules. And, a cathode layer **500** is formed on the electron injection layer **340** by vacuum deposition. An encapsulation or passivation layer is then formed.

On the other hand, the anode layer **200** may be formed on the large-scaled substrate **100** prior to the auxiliary electrodes **600** in the second embodiment of the present invention.

Operation of the passive type OLED according to the first and second embodiments of the present invention is explained as follows. When a voltage is applied to anode and cathode electrodes, holes injected through the hole transport layer meet electrons injected through the electron transport layer at the electroluminescent layer so as to be combined with each other. Then, the excited electrons drop to a ground state so as to emit light.

In the first and second embodiments of the present invention, at least one OLED is fabricated on the small substrate of 370 mm×470 mm separated from the large-scaled substrate of 740 mm×940 mm in accordance with its size.

And, a size of the large-scaled substrate used for the first or second embodiment of the present invention may be greater or smaller than 740 mm×940 mm. Besides, a size of each of the small substrates separated from the large-scaled substrate may be greater or smaller than 370×470 mm in consideration of the various deposition equipments. Moreover, the number of the small substrates is unnecessary to be four, which may be greater or smaller than four. And, the substrate includes a wafer and the like as well as the transparent substrate.

#### Third Embodiment

A method of fabricating an active type organic electroluminescent display according to a third embodiment of the present invention is described as follows.

Count and arrangement of transistors and capacitors in an active type OLED vary in accordance with the structure thereof. Hereinafter, a method of fabricating an active type OLED including driving transistors, switching transistors, and capacitors is explained in the following description.

FIG. 3A and FIG. 3B illustrate cross-sectional view of fabricating active type OLED according to a third embodiment of the present invention.

A dielectric layer (not shown in the drawing) is formed on a large-scaled substrate **100** using silicon oxide (SiO<sub>2</sub>). And, an active layer **810** of polysilicon is formed on the dielectric layer. In this case, the dielectric layer is formed by sputtering or chemical vapor deposition. And, the active layer **810** is formed by depositing a silicon layer by sputtering or CVD and then carrying out laser annealing on the silicon layer so as to form a polysilicon layer.

The active layer **810** is then patterned like islands using photolithography. A gate insulating layer **820** is formed on

the active layer **810** and the dielectric layer by sputtering or CVD. A metal layer is formed on the gate insulating layer **820** by sputtering or CVD, and then patterned so as to form a gate electrode **830**. In this case, the gate electrode **830** remains on the gate insulating layer **820** corresponding to the active layer **810**.

Ion doping and thermal treatment are carried out on the active layer **810** so as to define source and drain regions (not shown in the drawing) at the active layer **810**. Subsequently, a second dielectric layer **840** is formed on the substrate **100** including the gate insulating layer **820** and gate electrode **830**. Portions of the second dielectric layer **840** and gate insulating layer **820** corresponding to the source and drain regions are then etched selectively so as to form contact holes.

Subsequently, bus and ITO electrodes **900** and **200** are formed in the contact holes corresponding to the source and drain regions of a driving thin film transistor, respectively. A signal line is formed on a bus electrode **900** of a source region of a switching thin film transistor, and a storage electrode is formed at the gate electrode of the driving device and the drain region of the switching device so as to be electrically connected to a capacitor. In this case, the ITO electrode **200** is used as the anode layer for organic electroluminescence.

In order to construct a display part on the fabricated driving part, a passivation layer **710** is formed on a top of the resulting structure having the driving part and a portion of the passivation layer **710** is then etched so as to expose a portion of the ITO electrode **200**.

When the active layer **810**, gate insulating layer **820**, gate electrode **830**, and so forth are formed on the large-scaled substrate **100**, a scribing lane (not shown in the drawing) is prepared to cut the large-scaled substrate **100**. A width of the scribing lane is between 50  $\mu\text{m}$ ~1 mm.

The 740 mm $\times$ 940 mm large-scaled substrate **100** is cut so as to be divided into four 370 mm $\times$ 470 mm small substrates **100'** suitable for deposition. The large-scaled substrate **100** is cut using one of laser, supersonic waves, diamond, and the like. In order to remove particles generated from the cutting process of the large-sized substrate **100**, a cleaning process is carried out using wet cleaning, dry cleaning of UV or plasma, or both wet and dry cleaning.

Subsequently, as is the case with the first or second embodiment of the present invention, hole injection, hole transport, electroluminescent, electron transport, and electron injection layers **310**, **320**, **400**, **330**, and **340** are formed on the small substrate **100'** of 370 mm $\times$ 470 mm. In this case, these layers are formed by vacuum deposition in case of low molecules or one of ink-jet, printing, and spin-coating in case of high molecules. And, a cathode layer **500** is formed on the electron injection layer **340** by vacuum deposition. An encapsulation or passivation layer is then formed so as to fabricate, as shown in FIG. **3B**, the active type OELD having the driving part.

In the third embodiment of the present invention, at least one OELD is fabricated on the small substrate of 370 mm $\times$ 470 mm separated from the large-scaled substrate of 740 mm $\times$ 940 mm in accordance with a size of the active type OELD.

And, a size of the large-scaled substrate used for the third embodiment of the present invention may be greater or smaller than 740 mm $\times$ 940 mm. Besides, a size of each of the small substrates separated from the large-scaled substrate may be greater or smaller than 370 $\times$ 470 mm in consideration of the various deposition equipments. Moreover, the

number of the small substrates is unnecessary to be four, which may be greater or smaller than four.

The cathode layer **500** can be formed prior to the ITO electrode **200** used as the anode layer. And, the substrate includes a silicon wafer and the like as well as the transparent substrate.

Operation of the active type OELD according to the third embodiment of the present invention is explained as follows. When a voltage is applied to anode and cathode electrodes of a pixel selected by a thin film transistor, holes injected through the hole transport layer meet electrons injected through the electron transport layer at the electroluminescent layer so as to be combined with each other. Then, the excited electrons drop to a ground state so as to emit light.

Accordingly, a method of fabricating OELD according to the present invention has the following advantages or effects.

The present invention is mainly divided into the foregoing process requiring no deposition or printing equipment for forming the organic luminescent and its auxiliary layers and the following process requiring the deposition or printing equipment for forming the organic luminescent and its auxiliary layers. After having been prepared and carrying out the foregoing process, the large-scaled substrate is cut into small substrates having sizes suitable for deposition or printing in order to form the electroluminescent and auxiliary layers requiring the deposition or printing equipment. Successively, the electroluminescent and auxiliary layers are formed on the small substrate by deposition or printing.

Such a method of fabricating OELD overcomes the limitation of the substrate size according to a chamber size of the deposition or printing equipment so as to carry out the foregoing processes on a large-scaled substrate. Therefore, the present invention enables to improve productivity as well as reduce product cost.

The foregoing embodiments are merely exemplary and are not to be construed as limiting the present invention. The present teachings can be readily applied to other types of apparatuses. The description of the present invention is intended to be illustrative, and not to limit the scope of the claims. Many alternatives, modifications, and variations will be apparent to those skilled in the art.

What is claimed is:

1. A method of fabricating an organic electroluminescent display, comprising the steps of:

forming a first electrode layer on a large-scaled substrate; dividing the large-scaled substrate into a plurality of small substrates;

forming an organic electroluminescent layer on the first electrode layer of at least one of the small substrates; and forming a second electrode layer on the organic electroluminescent layer.

2. The method of claim 1, before dividing the large-scaled substrate, the method further comprising the steps of:

forming an ITO layer as the first electrode layer on the large-scaled substrate;

forming a dielectric layer having a plurality of openings exposing portions of the ITO layer; and

forming a plurality of separators on the dielectric layer so as to be vertical to the ITO layer.

3. The method of claim 1, wherein a size of the large-scaled substrate is 740 mm $\times$ 940 mm and a size of each of the small substrates is 370 mm $\times$ 470 mm.

4. The method of claim 1, wherein the large-scaled substrate is divided using one of laser, supersonic waves, and diamond.

## 9

5. The method of claim 1, further comprising the step of carrying out a cleaning process after dividing the large-sized substrate.

6. The method of claim 1, wherein the first and second electrode layers are used as anode and cathode layers, respectively, and vice versa.

7. The method of claim 1, further comprising the step of forming a subsidiary electrode layer beneath or onto the first electrode layer.

8. The method of claim 1, wherein the organic electroluminescent layer includes hole injection, hole transport, electroluminescent, and electron injection layers.

9. The method of claim 1, further comprising the step of forming an encapsulation or passivation layer on the second electrode layer.

10. A method of fabricating an organic electroluminescent display, comprising the steps of:

forming a driving part including a plurality of transistors and at least one capacitor and having a first electrode layer on a large-scaled substrate;

dividing the large-scaled substrate into a plurality of small substrates;

forming an organic electroluminescent layer on the first electrode layer of the driving part of at least one of the small substrates; and

forming a second electrode layer on the organic electroluminescent layer.

11. The method of claim 10, wherein a cutting area is prepared to divide the large-scaled substrate and a width of the cutting area lies between 50  $\mu\text{m}$ ~1 mm.

12. The method of claim 10, wherein the driving part on the large-scaled substrate comprises a driving transistor, a switching transistor, and a capacitor.

13. The method of claim 10, the step of forming the driving part comprising the steps of:

## 10

forming a dielectric layer and an active layer on the large-scaled substrate in order;

forming a gate insulating layer on the active layer and the dielectric layer;

forming a gate electrode on the gate insulating layer corresponding to the active layer;

forming a source and a drain at the active layer;

forming a second dielectric layer on the large-scaled substrate including the gate insulating layer and gate electrode;

forming contact holes by etching selectively the second dielectric and gate insulating layers corresponding to the source and drain;

forming bus and first electrodes at the contact holes corresponding the source and drain of the driving transistor, respectively; and

forming a signal line on the bus electrode of the source of the switching transistor and a storage electrode at the gate electrode of the driving transistor and the drain of the switching transistor so as to be connected to the capacitor.

14. The method of claim 10, wherein the first and second electrode layers are used as anode and cathode layers, respectively, and vice versa.

15. The method of claim 10, wherein the organic electroluminescent layer includes hole injection, hole transport, electroluminescent, and electron injection layers.

16. The method of claim 10, further comprising the step of forming one of encapsulation and passivation layers on the second electrode layer.

\* \* \* \* \*

专利名称(译)	制造有机电致发光显示器的方法		
公开(公告)号	<a href="#">US6610554</a>	公开(公告)日	2003-08-26
申请号	US10/119780	申请日	2002-04-11
[标]申请(专利权)人(译)	易刘承俊 CHOI DO HYUN 崔庆熙		
申请(专利权)人(译)	易SEUNG-JUN 崔DO-HYUN 崔京姬		
当前申请(专利权)人(译)	KIM , HYUNG SE		
[标]发明人	YI SEUNG JUN CHOI DO HYUN CHOI KYUNG HEE		
发明人	YI, SEUNG-JUN CHOI, DO-HYUN CHOI, KYUNG-HEE		
IPC分类号	H01L27/28 H01L51/56 H01L27/32 H01L51/50 H01L51/52 H05B33/10 G09F9/00 G09F9/30 H01L21/336 H01L29/786 H05B33/02 H05B33/12 H05B33/22 H05B33/26 H01L21/00		
CPC分类号	H01L27/3244 H01L27/3281 H01L51/56 H01L27/3211 H01L27/3283 H01L51/5212 H01L2251/566		
审查员(译)	SMITH , MATTHEW		
优先权	1020010020689 2001-04-18 KR 1020020014622 2002-03-18 KR		
其他公开文献	US20020187255A1		
外部链接	<a href="#">Espacenet</a> <a href="#">USPTO</a>		

摘要(译)

描述了一种制造有机电致发光显示器(下文简称为OELD)的方法,该方法能够通过进行前述OELD工艺,分割大型基板,并按顺序执行下面的OELD工艺来提高生产效率。本发明包括以下步骤:在大尺寸基板上形成第一电极层,将大尺寸基板分成多个小基板,在至少一个小基板的第一电极层上形成有机电致发光层,并在有机电致发光层上形成第二电极层。

